

DIESEL ENGINE-GENERATOR SET

275-XC6DT3

275 kWe / 60 Hz / Standby
260 kWe / 60 Hz / Prime
208 - 600V



SYSTEM RATINGS

Standby

Voltage (L-L)	240V**	208V**	240V**	480V**	600V**
Phase	1	3	3	3	3
PF	1.0	0.8	0.8	0.8	0.8
Hz	60	60	60	60	60
kW	275	275	275	275	275
kVA	275	343.75	343.75	343.75	343.75
AMPS	1146	954	827	413	331
skVA@30%					
Voltage Dip	470	520	520	700	720
Generator Model*	572RSL4027	432CSL6210	432CSL6210	432CSL6210	432PSL6246
Temp Rise	130°C/27°C	130°C/27°C	130°C/27°C	130°C/27°C	125°C/40°C
Connection	12 LEAD ZIG-ZAG	12 LEAD LOW WYE	12 LEAD HI DELTA	12 LEAD HI WYE	4 LEAD WYE

Prime

Voltage (L-L)	240V	208V	240V	480V	600V
Phase	1	3	3	3	3
PF	1.0	0.8	0.8	0.8	0.8
Hz	60	60	60	60	60
kW	260	260	260	260	260
kVA	260	325	325	325	325
AMPS	1021	902	782	391	313
skVA@30%					
Voltage Dip	470	520	520	700	720
Generator Model*	572RSL4027	432CSL6210	432CSL6210	432CSL6210	432PSL6246
Temp Rise	105°C/40°C	105°C/40°C	105°C/40°C	105°C/40°C	105°C/40°C
Connection	12 LEAD ZIG-ZAG	12 LEAD LOW WYE	12 LEAD HI DELTA	12 LEAD HI WYE	4 LEAD WYE

* The Generator Model Number identified in the table is for standard C Series Configuration. Consult the factory for alternate configuration.

** UL2200 Offered

STANDARD FEATURES

- // EPA Tier 3 Certified
- // Engine-Generator Set Tested to ISO 8528-5 for Transient Response
- // UL2200, CSA Listing Offered
- // Accepts Rated Load in One Step Per NFPA 110
- // All engine-generator sets are prototype and factory tested
- // MTU Onsite Energy is a single source supplier
- // Global Product Support
- // 2 Year Standard Warranty
- // Series 60 (6063HV35) Diesel Engine
 - 14.0 Liter Displacement
 - Electronic Unit Pump Injection
 - 4-Cycle
- // Complete Range of Accessories
- // Permanent Magnet Generator (PMG)
 - Brushless, Rotating Field
 - 300% Short Circuit Capability
 - 2/3 Pitch Windings
 - Standard for 570 frame and larger
 - Optional for 430 frame and smaller
- // Digital Control Panel(s)
 - UL Recognized,  us, NFPA 110
 - Complete System Metering
 - LCD Display
- // Cooling System
 - Integral Set-Mounted
 - Engine Driven Fan

STANDARD EQUIPMENT

// Engine

.....
 Air Cleaners
 Oil Pump
 Full Flow Oil Filter
 Jacket Water Pump
 Thermostat
 Exhaust Manifold - Dry
 Blower Fan & Fan Drive
 Radiator - Unit Mounted
 Electric Starting Motor - 24V
 Governor - Electronic Isochronous
 Base - Formed Steel
 SAE Flywheel & Bell Housing
 Charging Alternator - 24V
 Battery Box & Cables
 Flexible Fuel Connectors
 Flexible Exhaust Connection
 EPA Certified Engine

// Generator

.....
 NEMA MG1, IEEE and ANSI standards compliance for temperature rise and motor starting
 Sustained short circuit current of up to 300% of the rated current for up to 10 seconds
 Self-Ventilated and Drip-Proof
 Superior Voltage Waveform
 Digital, Solid State, Volts-per-Hertz Regulator
 No Load to Full Load Regulation

.....
 Brushless Alternator with Brushless Pilot Exciter
 4 Pole, Rotating Field
 130°C Standby Temperature Rise
 1 Bearing, Sealed
 Flexible Coupling
 Full Amortisseur Windings
 125% Rotor Balancing
 3-Phase Voltage Sensing
 ± 1% Voltage Regulation
 100% of Rated Load - One Step
 3% Maximum Harmonic Content

// Digital Control Panel(s)

.....
 Digital Metering
 Engine Parameters
 Generator Protection Functions
 Engine Protection
 SAE J1939 Engine ECU Communications
 Windows-Based Software
 Multilingual Capability
 Remote Communications to our RDP-110 Remote Annunciator
 16 Programmable Contact Inputs
 7 Contact Outputs
 UL Recognized,  us, CE Approved
 Event Recording
 IP 54 Front Panel Rating with Integrated Gasket
 NFPA110 Level Compatible

APPLICATION DATA

// Engine

Manufacturer	Detroit Diesel
Model	Series 60 (6063HV35)
Type	4-Cycle
Arrangement	6-Inline
Displacement: L (in ³)	14 (855)
Bore: cm (in)	13.3 (5.24)
Stroke: cm (in)	16.8 (6.61)
Compression Ratio	16:1
Rated RPM	1,800
Engine Governor	DDEC
Maximum Power: Standby: kWm (bhp)	366 (490)
Maximum Power: Prime: kWm (bhp)	316 (424)
Speed Regulation	±0.25%
Air Cleaner	Dry

// Liquid Capacity (Lubrication)

Total Oil System: L (gal)	36 (9.5)
Engine Jacket Water Capacity: L (gal)	23 (6)
System Coolant Capacity: L (gal)	159 (42)

// Electrical

Electric Volts DC	24
Cold Cranking Amps Under -17.8°C (0°F)	950

// Fuel System

Fuel Supply Connection Size	1/2" NPT
Fuel Return Connection Size	1/2" NPT
Maximum Fuel Lift: m (ft)	6.7 (2.1)
Recommended Fuel	Diesel #2
Total Fuel Flow: L/hr (gal/hr)	329 (86.9)

// Fuel Consumption

	STANDBY	PRIME
At 100% of Power Rating: L/hr (gal/hr)	96 (25.4)	86 (22.7)
At 75% of Power Rating: L/hr (gal/hr)	76 (20.2)	66 (17.3)
At 50% of Power Rating: L/hr (gal/hr)	52 (13.7)	44 (11.6)

// Cooling - Radiator System

	STANDBY	PRIME
Ambient Capacity of Radiator: °C (°F)	50 (122)	50 (122)
Maximum Restriction of Cooling Air, Intake, and Discharge Side of Rad.: kPa (in. H ₂ O)	0.12 (0.5)	0.12 (0.5)
Water Pump Capacity: L/min (gpm)	363 (96)	363 (96)
Heat Rejection to Coolant: kW (BTUM)	140 (7,950)	123 (7,000)
Heat Rejection to Air to Air: kW (BTUM)	90 (5,150)	83 (4,750)
Heat Radiated to Ambient: kW (BTUM)	90 (5,094)	87 (4,947)

// Air Requirements

	STANDBY	PRIME
Aspirating: *m ³ /min (SCFM)	31 (1,105)	30 (1,070)
Air Flow Required for Rad.		
Cooled Unit: *m ³ /min (SCFM)	535 (18,891)	535 (18,891)
Air Flow Required for Heat Exchanger/Remote Rad. based on 25°F Rise: *m ³ /min (SCFM)	327 (11,487)	318 (1,156)

* Air density = 1.184 kg/m³ (0.0739 lbf/ft³)

// Exhaust System

	STANDBY	PRIME
Gas Temp. (Stack): °C (°F)	507 (944)	466 (871)
Gas Volume at Stack		
Temp: m ³ /min (CFM)	82 (2,903)	75 (2,657)
Maximum Allowable		
Back Pressure: kPa (in. H ₂ O)	10.16 (40.8)	10.16 (40.8)

WEIGHTS AND DIMENSIONS

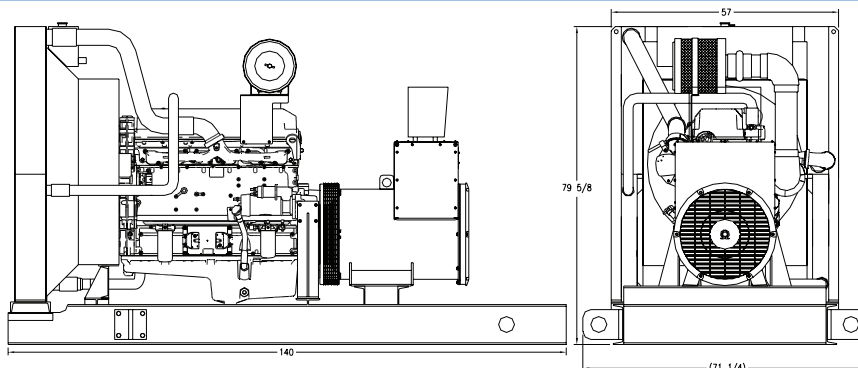

Drawing above for illustration purposes only, based on standard open power 480 volt engine-generator set. Lengths may vary with other voltages. Do not use for installation design. See website for unit specific template drawings.

System

OPU

Dimensions (L x W x H)

3,560 x 1,450 x 2,020 mm (140 x 57 x 79.6 in)

Weight (less tank)

2,649 kg (5,841 lb)

Weights and dimensions are based on open power units and are estimates only. Consult the factory for accurate weights and dimensions for your specific engine-generator set.

SOUND DATA

Unit Type	Standby Full Load	Standby No Load	Prime Full Load	Prime No Load
OPU w/Critical Grade Muffler (dBA)	94.5	87	93	87
Sound Attenuated Enclosure (dBA)	86.5	79	85	79

Sound data is provided at 7 m (23 ft).

EMISSIONS DATA

NO_x + NMHC	CO	PM
2.74	0.56	0.09

All units are in g/hp-hr and are EPA D2 cycle values.

Emission levels of the engine may vary as a function of ambient temperature, barometric pressure, humidity, fuel type and quality, installation parameters, measuring instrumentation, etc. The data provided are laboratory results from one engine representing this rating. The data was obtained under controlled environmental conditions with calibrated instrumentation traceable to the United States National Bureau of Standards and in compliance with US EPA regulations found within 40 CFR Part 89. The weighted cycle value from each engine is guaranteed to be below the US EPA Standards at the US EPA defined conditions.

RATING DEFINITIONS AND CONDITIONS

- // Standby ratings apply to installations served by a reliable utility source. The standby rating is applicable to varying loads for the duration of a power outage. No overload capability for this rating. Ratings are in accordance with ISO-3046/1, BS 5514, AS 2789, and DIN 6271.
- // Prime power ratings apply to installations where utility power is unavailable or unreliable. At varying load, the number of generator set operating hours is unlimited. A 10% overload capacity is available for one hour in twelve. Ratings are in accordance with ISO-8528/1, overload power in accordance with ISO-3046/1, BS 5514, AS 2789, and DIN 6271. For limited running time and base load ratings, consult the factory.
- // Deration Factor:
 - Altitude:** 1% per 305 m (1,000 ft) above 183 m (600 ft). Consult your local MTU Onsite Energy Power Generation Distributor for other altitudes.
 - Temperature:** 1% per 5.5°C (10°F) above 25°C (77°F).

Materials and specifications subject to change without notice.

C/F = Consult Factory/MTU Onsite Energy Distributor